

**Clavija 2P+T, 16A 250V~. Caucho color negro.**

Clavija 2P+T, 16A,250V. Espigas de Ø4,8mm. Con prensaestopa. Caucho negro. IP54

**Características**

Aplicaciones habituales	Entorno domestico/terciario exterior (jardín, piscina, parking, vía publica etc..)
Material	Caucho
Tipo	Clavija
Nº de polos	2P + T
Tipo de embornamiento	Por tornillo
Corriente nominal	16A
Toma de tierra	Doble sistema
Sujetacable abatible para facilitar embornamiento	Sí
Posibilidad utilizar cable 3x2,5mm <sup>2</sup>	Sí
Corriente nominal	16A
Tensión nominal	250V~
Color	Negro-azul

**Datos técnicos**

Grado de protección (IP)	IP54
Resistencia al fuego (GWEPT)	650/750 °C
Resistencia al calor (Presión bola)	70/125 °C
Libre de halógenos	Sí

**Normativa**

Marcado CE	Sí
Marcado CMim	Sí
Conforme a Normativa UNE/EN	UNE-20315-1-1:2017; UNE-20315-1-2:2017

---

Conforme a Reglamento Electrotecnico de Baja Tension (REBT)	Sí
---	----

---

Conforme al Reglamento (UE) 2023/988 del Parlamento Europeo y del Consejo relativo a la seguridad general de los productos	Sí
--	----

---

## Sostenibilidad

---

Conforme Directiva Europea 2011/65/UE (RoHS)	Sí
--	----

---

Conforme Directiva europea 2012/19/UE (RAEE2)	Sí
---	----

---

Conforme a Normativa (RoHS)	UNE-EN IEC 63000:2022
-----------------------------	-----------------------

---

## Logística y embalaje

---

Código EAN unitario	8423220205024
---------------------	---------------

---

Código EAN envase	8423220205000
-------------------	---------------

---

Código EAN embalaje	18423220205007
---------------------	----------------

---

Uds. Envase	13
-------------	----

---

Uds. Embalaje	208
---------------	-----

---

Uds. Pallet	7280
-------------	------

---

Medidas Envase cm	14,5x8,8x19
-------------------	-------------

---

Medidas Embalaje cm	59,5x37,5x20
---------------------	--------------

---

Peso unitario (g)	41,4
-------------------	------

---

Peso Envase (Kg)	0,1055
------------------	--------

---

Peso Embalaje (Kg)	10,1768
--------------------	---------

---

Código arancelario	85366990
--------------------	----------

---

## Croquis

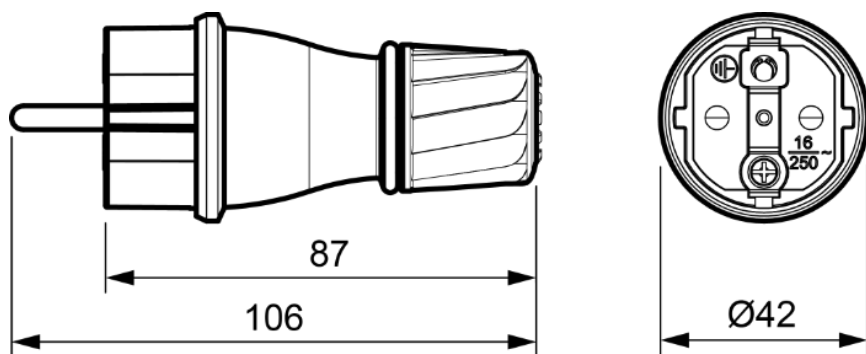

## Documentación y descargas

-  [Instrucciones de montaje \(2.9MB\)](#)
-  [Información de seguridad \(0.38MB\)](#)
-  [Documentación comercial \(0.92MB\)](#)