

Base fija 2P+T, 16A 250V~. Color blanco.

Base fija 2P+T, 16A 250V~. Color blanco.De superficie.

**Características**

Aplicaciones habituales	Entorno domestico/terciario interior (Interior de vivienda, oficinas, comercios, etc..)
Material	Termoplástico
Tipo	Base fija
Nº de polos	2P + T
Tipo de embornamiento	Por tornillo
Corriente nominal	16A
Toma de tierra	Lateral
Corriente nominal	16A
Tensión nominal	250V~
Color	Blanco

Datos técnicos

Resistencia al fuego (GWEPT)	650/750 °C
Resistencia al calor (Presión bola)	70/125 °C
Libre de halógenos	Sí

Normativa

Marcado CE	Sí
Conforme a Normativa UNE/EN	UNE-20315-1-1:2017; UNE-20315-1-2:2017

Conforme a Reglamento Electrotecnico de Baja Tension (REBT)	Sí
---	----

Conforme al Reglamento (UE) 2023/988 del Parlamento Europeo y del Consejo relativo a la seguridad general de los productos	Sí
--	----

Sostenibilidad

Conforme Directiva Europea 2011/65/UE (RoHS)	Sí
--	----

Conforme Directiva europea 2012/19/UE (RAEE2)	Sí
---	----

Conforme a Normativa (RoHS)	UNE-EN IEC 63000:2022
-----------------------------	-----------------------

Logística y embalaje

Código EAN unitario	8423220079335
---------------------	---------------

Código EAN envase	8423220005174
-------------------	---------------

Código EAN embalaje	18423220005171
---------------------	----------------

Uds. Envase	12
-------------	----

Uds. Embalaje	192
---------------	-----

Uds. Pallet	6720
-------------	------

Medidas Envase cm	14,5x8,8x19
-------------------	-------------

Medidas Embalaje cm	59,5x37,5x20
---------------------	--------------

Peso unitario (g)	52,2
-------------------	------

Peso Envase (Kg)	0,6734
------------------	--------

Peso Embalaje (Kg)	11,3544
--------------------	---------

Código arancelario	85366990
--------------------	----------

Croquis

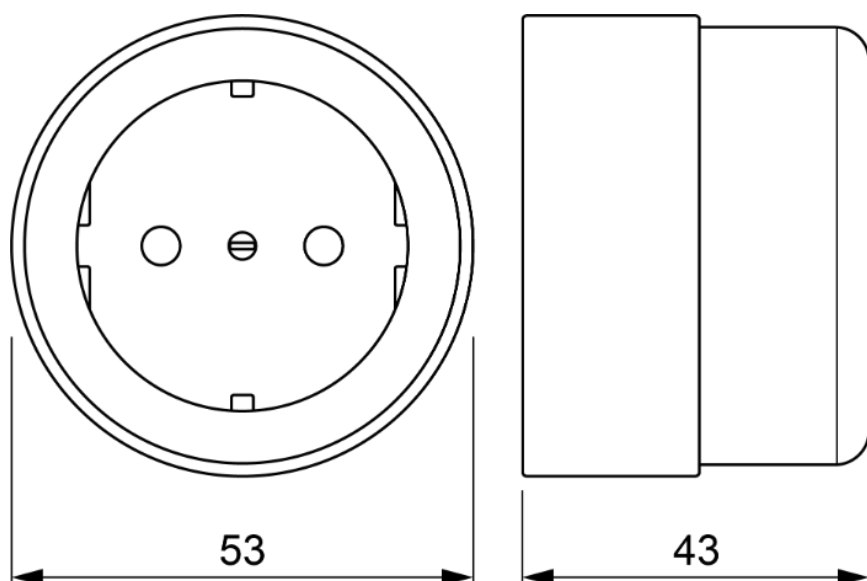

Documentación y descargas

-  Documentación comercial (0.92MB)
-  Información de seguridad (0.38MB)