

Socket 2P+E (French), 16A 250V ~ + 2-way switch 10AX 250V~. Surface.

Socket 2P+E (French), 16A 250V ~ + 2-way switch 10AX 250V~. Surface. White colour. Dimensions 138 x 72 x 42 mm. Inputs for 10x16, 10x20 and 16x16 mm mini-trunking. Screw connection.



Features

Common applications	Indoor domestic / tertiary environment (Interior of home, offices, shops, etc.)
Mechanism type	switch + fixed base
Type of installation	Surface
Nominal voltage	250V~ (50/60 Hz)
Connection type	Screw connection
Mini trunking input	Yes
Type of operation	Rocker key
Dimensions	138 x 72 x 42
Monobloc (with frame included)	Yes
Frame color	White

Technical data

Fire resistance (GWEPT)	750/850 °C
Installation temperature	-5 °C -> +60 °C
Free of halogens	Yes

Regulations

CE marking	Yes
According to Regulations	NF C61-314
According to Regulations UNE/EN	UNE-EN 60669-1:2018 UNE 20315-1-1:2017 UNE-20315-1-2:2017

In accordance with the Low Voltage Electrotechnical Regulations (REBT)	Yes
--	-----

According to European Directive 2014/35 / EU. Low voltage directive	Yes
---	-----

Sustainability

According to European Directive 2011/65/UE (RoHS)	Yes
---	-----

According to European Directive 2012/19/UE (RAEE2)	Yes
--	-----

According to Regulations (RoHS)	UNE-EN IEC 63000:2022
---------------------------------	-----------------------

Logistics and packaging

Unit EAN code	8423220220294
---------------	---------------

EAN code container	8423220220300
--------------------	---------------

EAN code packaging	18423220220307
--------------------	----------------

Units packaging	10
-----------------	----

Units carton	120
--------------	-----

Pallet Units	5760
--------------	------

Packaging Measurements cm	16x18x8
---------------------------	---------

Packaging Measures cm	49,5x19x34
-----------------------	------------

Unit weight (g)	65,2
-----------------	------

Container Weight (Kg)	0,784
-----------------------	-------

Packaging Weight (Kg)	10,008
-----------------------	--------

Tariff code	85366990
-------------	----------

Sketch

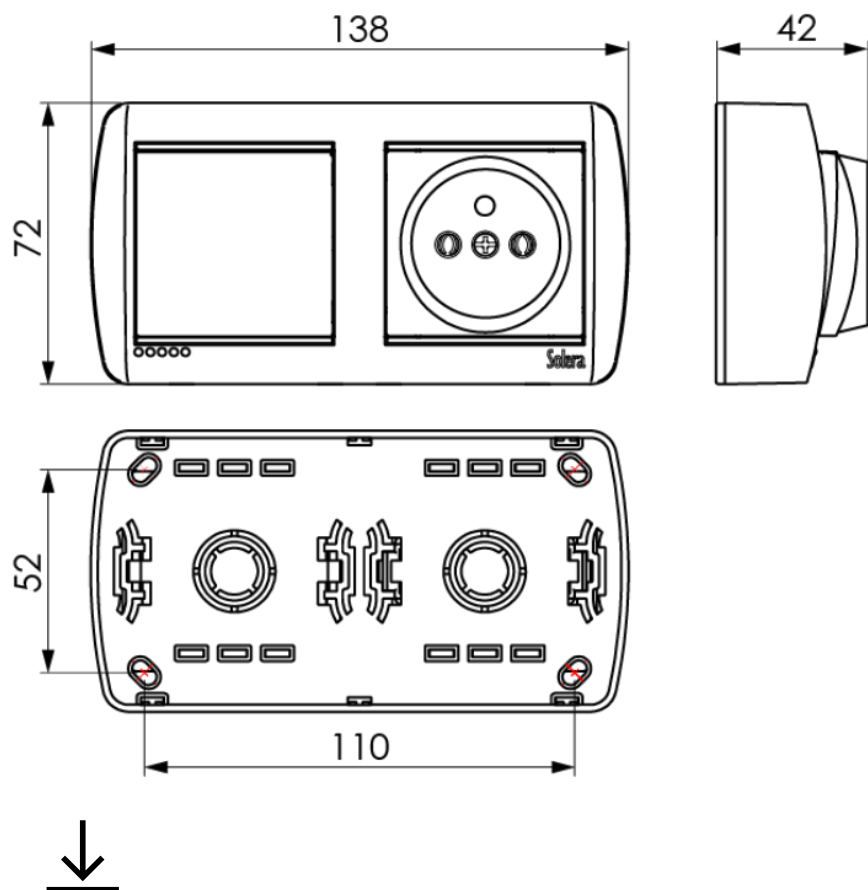

Documentation and downloads



Commercial doc. (2.65MB)



Safety Information (0.38MB)



Surface switches Mural range (Solera)



Assembly surface switches Mural range (Solera)