

## Socket 2P+E, 16A 250V~. Surface.

Socket 2P+E, 16A 250V~. Surface. White colour. Inputs for 10x16, 10x20 and 16x16 mm mini-trunking.



## Features

Common applications	Indoor domestic / tertiary environment (Interior of home, offices, shops, etc.)
Mechanism type	Fixed base
Type of installation	Surface
Rated current	16A
Nominal voltage	250V~ (50/60 Hz)
Connection type	Screw connection
Mini trunking input	Yes
Dimensions	74 x 72 x 42
Monobloc (with frame included)	Yes
Frame color	White

## Technical data

Fire resistance (GWEPT)	750/850 °C
Installation temperature	-5 °C -> +60 °C
Free of halogens	Yes

## Regulations

CE marking	Yes
According to Regulations UNE/EN	UNE-20315-1-1:2017; UNE-20315-1-2:2017

In accordance with the Low Voltage Electrotechnical Regulations (REBT)	Yes
TÜV Rheinland certificate	Yes
In accordance with the Regulation (EU) 2023/988 of the European Parliament and of the Council on general product safety	Yes

## Sustainability

According to European Directive 2011/65/UE (RoHS)	Yes
According to European Directive 2012/19/UE (RAEE2)	Yes
According to Regulations (RoHS)	UNE-EN IEC 63000:2022

## Logistics and packaging

Unit EAN code	8423220082700
EAN code container	8423220082618
EAN code packaging	18423220082615
Units packaging	10
Units carton	120
Pallet Units	4800
Packaging Measurements cm	22,5x16x8
Packaging Measures cm	49,5x23,5x34
Unit weight (g)	63,76
Container Weight (Kg)	0,7856
Packaging Weight (Kg)	10,0942
Tariff code	85366990

## Sketch

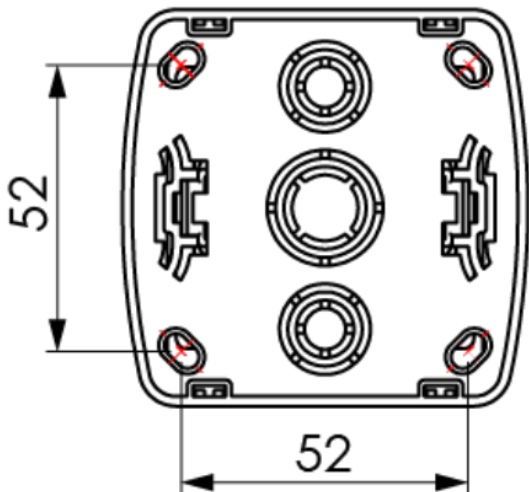
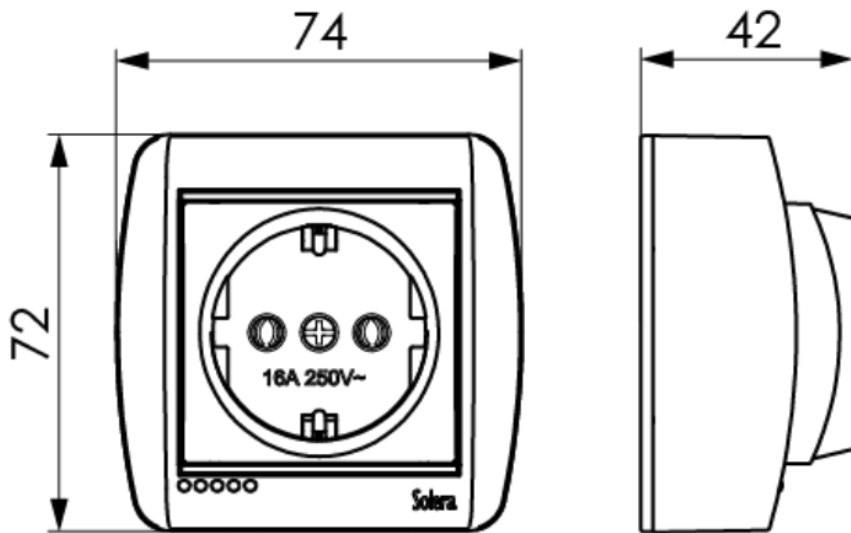

## Documentation and downloads



Commercial doc. (2.65MB)



Surface switches Mural range (Solera)



Safety Information (0.38MB)



Assembly surface switches Mural range (Solera)