

2-way switch / light switch 10AX 250V~. Surface.

2-way switch / light switch 10AX 250V~. Surface. Graphite colour. Dimensions 74 x 72 x 28 mm. Inputs for 10x16, 10x20 and 16x16 mm mini-trunking. Screw connection.



Features

Common applications	Indoor domestic / tertiary environment (Interior of home, offices, shops, etc.)
Mechanism type	Switch
Type of installation	Surface
Pilot light	Yes
Rated current	10AX
Nominal voltage	250V~ (50/60 Hz)
Connection type	Screw connection
Mini trunking input	Yes
Type of operation	Rocker key
Dimensions	74 x 72 x 28
Monobloc (with frame included)	Yes
Frame color	Graphite

Technical data

Fire resistance (GWEPT)	750/850 °C
Installation temperature	-5 °C -> +60 °C
Free of halogens	Yes

Regulations

CE marking	Yes
UK marking	Yes
CMim marking	Yes
According to Regulations UNE/EN	UNE-EN 60669-1:2018
In accordance with the Low Voltage Electrotechnical Regulations (REBT)	Yes
TÜV Rheinland certificate	Yes
According to European Directive 2014/35 / EU. Low voltage directive	Yes

Sustainability

According to European Directive 2011/65/UE (RoHS)	Yes
According to European Directive 2012/19/UE (RAEE2)	Yes
According to Regulations (RoHS)	UNE-EN IEC 63000:2022

Logistics and packaging

Unit EAN code	8423220263277
EAN code container	8423220263260
Units packaging	10
Units carton	120
Pallet Units	5760
Packaging Measurements cm	16x18x8
Packaging Measures cm	49,5x19x34
Unit weight (g)	66,6
Container Weight (Kg)	0,798
Packaging Weight (Kg)	10,176
Tariff code	85366990

Sketch

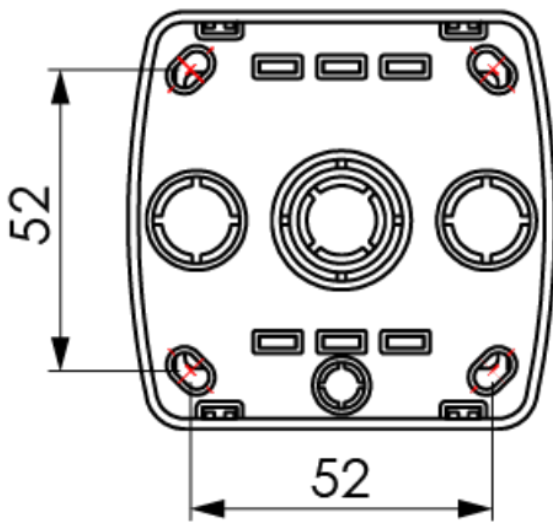
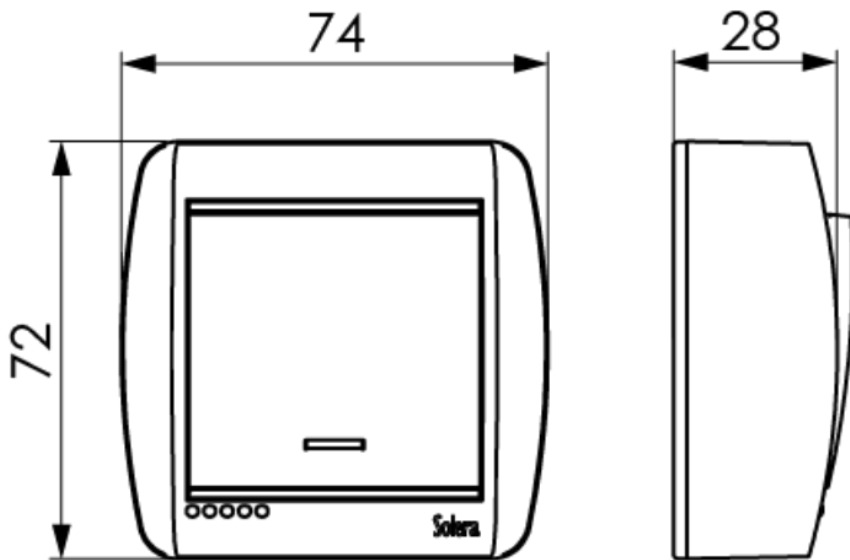

Documentation and downloads



Commercial doc. (3.58MB)



Surface switches Mural range (Solera)



Safety Information (0.38MB)



Assembly surface switches Mural range (Solera)