

## Crossover switch 10AX 250V~. Flush.

Crossover switch 10AX 250V~. Flush.White colour. Without frame. Quick connection.



## Features

Common applications	Indoor domestic / tertiary environment (Interior of home, offices, shops, etc.)
Mechanism type	Crossover switch
Type of installation	Flush
Rated current	10AX
Nominal voltage	250V~ (50/60 Hz)
Connection type	Fast connection
Flexible cable section	Up to 2.5 mm <sup>2</sup>
Rigid cable section	Up to 2.5 mm <sup>2</sup>
Type of operation	Rocker key
With fixing claws	Yes

## Technical data

Fire resistance (GWEPT)	850 °C
Heat resistance (Ball pressure)	70/125 °C
Free of halogens	Yes

## Regulations

CE marking	Yes
UK marking	Yes
CMim marking	Yes

According to Regulations UNE/EN	UNE-EN 60669-1:2018
In accordance with the Low Voltage Electrotechnical Regulations (REBT)	Yes
TÜV Rheinland certificate	Yes
According to European Directive 2014/35 / EU. Low voltage directive	Yes

## Sustainability

According to European Directive 2011/65/UE (RoHS)	Yes
According to European Directive 2012/19/UE (RAEE2)	Yes
According to Regulations (RoHS)	UNE-EN IEC 63000:2022

## Logistics and packaging

Unit EAN code	8423220094321
EAN code container	8423220080980
EAN code packaging	18423220080987
Units packaging	10
Units carton	120
Pallet Units	4320
Packaging Measurements cm	25,2x14x8
Packaging Measures cm	44,5x26,8x32,2
Unit weight (g)	73,2
Container Weight (Kg)	0,8716
Packaging Weight (Kg)	11,0722
Tariff code	85366990

## Sketch

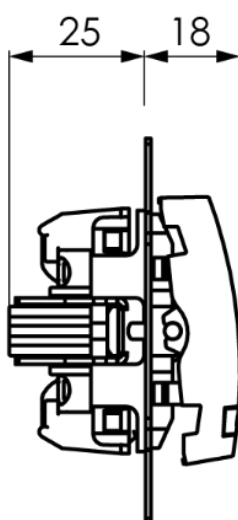
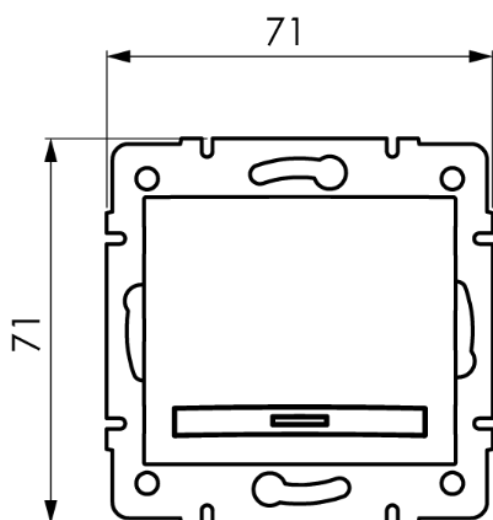

## Documentation and downloads



Commercial doc. (3.28MB)



Safety Information (0.38MB)



Flush switches of Eruopa range (Solera)



Assembly flush switches form Europa range (Solera)