

Watertight connection box 310 x 240 x 125 mm without cones. Grey colour with clear lid and DIN rail.

Watertight connection box without cones in grey, sized 310 x 240 x 125 mm. Designed for secure cable junctions in demanding indoor or outdoor installations, it provides IP65 protection and IK09 impact resistance. The plastic threaded screws provide dependable closing and help maintain the seal. The clear lid makes visual inspection easier without opening the box. It includes a 35 mm DIN rail for mounting modular devices.



Features

Installation method	Surface
Use	Domestic / Tertiary
Location type	Exterior and interior
Metallic DIN profile	Yes
Dimensions outside (mm) (width x height x depth)	320x250x135
Dimensions inside (mm) (Width x Height x Depth)	310x240x125
Case material	Insulation
Case color	Grey (RAL7035)
Cap color	Grey (RAL 7035)
Ticket type	Smooth sides (machining inlets)
Fixation System (For surface)	Exterior
Sealable	Yes
Lid closure system	Plastic screw
Possibility of mounting strips	Yes (not included)
Possibility of mounting plate	Yes (not included)
Possibility of mounting DIN rail	Yes (included)
Captive screw	Yes

Captive Lid	Yes
Valid for photovoltaic installations	Yes
Common applications	Industrial environments (factories, warehouses, etc.)

Technical data

Protection Degree (IK)	IK09
Impact shock resistance	Strong
Insulation class	Class II
Fire resistance (GWEPT)	650 °C
Heat resistance (Ball pressure)	70 °C
Ambient operating temperature	-5 °C ; +60 °C
Work stress	<1000 Vac ; 1500 Vdc
UV resistance	Yes
Free of halogens	Yes

Regulations

CE marking	Yes
UK marking	Yes
CMim marking	Yes
According to Regulations UNE/EN	UNE-EN 60670-1:2022 UNE- EN 60670-22:2007
In accordance with the Low Voltage Electrotechnical Regulations (REBT)	Yes
APPlus certificate	Yes
According to European Directive 2014/35 / EU. Low voltage directive	Yes

Sustainability

According to European Directive 2011/65/UE (RoHS)	The Directive 2011/65/EU (RoHS II) is not applicable as it does not correspond to the definition of Electrical and Electronical Equipment (EEE) as per article 3.1
According to European Directive 2012/19/UE (RAEE2)	Not applicable because it does not meet the definition of Electrical and Electronic Equipment (EEE) as described in Article 3.1(a) of Directive 2012/19/EU (WEEE II).

Logistics and packaging

Unit EAN code	8423220001039
EAN code container	8423220001039
EAN code packaging	18423220001036
Units packaging	1
Units carton	12
Pallet Units	180
Packaging Measures cm	59,5x39,5x59,5
Unit weight (g)	1195
Container Weight (Kg)	1,202
Packaging Weight (Kg)	15,554
Tariff code	85381000

Sketch

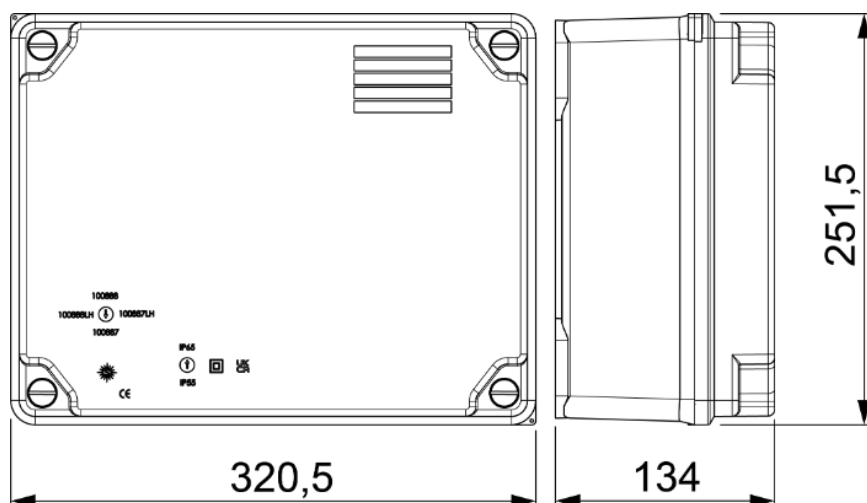

Documentation and downloads

- Assembly instructions (1.11MB)
- Safety Information (0.38MB)
- Commercial doc. (2.73MB)
- Mounting junction boxes (Solera)
- Junction boxes IP65/55, IK07-08-09 (Solera)

