

Surface mechanism box for 3 modules, 235 x 96 x 43 mm. Graphite color.

Surface mechanism box for 3 modules, 235 x 96 x 43 mm. White colour. Includes expansion plug and screw. Inputs for 10x16, 10x20, 16x25 and 25x40 mm trunking.



Features

Installation method	Surface
Use	Domestic / Tertiary
Location type	Inside
No. Modules (18 mm)	3
Dimensions outside (mm) (width x height x depth)	235x96x43
Case material	Insulation
Case color	Graphite
Fixation System (For surface)	Inside
Common applications	Indoor domestic / tertiary environment (Interior of home, offices, shops, etc.)

Technical data

Insulation class	Class II
Fire resistance (GWEPT)	650 °C
Free of halogens	Yes

Regulations

CE marking	Yes
UK marking	Yes
CMim marking	Yes
According to Regulations UNE/EN	UNE-EN 60670-1:2022 UNE- EN 60670-22:2007

In accordance with the Low Voltage Electrotechnical Regulations (REBT) Yes

According to European Directive 2014/35 / EU. Low voltage directive Yes

Sustainability

According to European Directive 2011/65/UE (RoHS) The Directive 2011/65/EU (RoHS II) is not applicable as it does not correspond to the definition of Electrical and Electronical Equipment (EEE) as per article 3.1

According to European Directive 2012/19/UE (RAEE2) Not applicable because it does not meet the definition of Electrical and Electronic Equipment (EEE) as described in Article 3.1(a) of Directive 2012/19/EU (WEEE II).

Logistics and packaging

Unit EAN code	8423220289819
EAN code container	8423220289819
EAN code packaging	18423220289816
Units packaging	1
Units carton	38
Pallet Units	1330
Packaging Measures cm	59,5x37,5x20
Unit weight (g)	145,8
Container Weight (Kg)	0,1458
Packaging Weight (Kg)	6,0804
Tariff code	85371098

Sketch

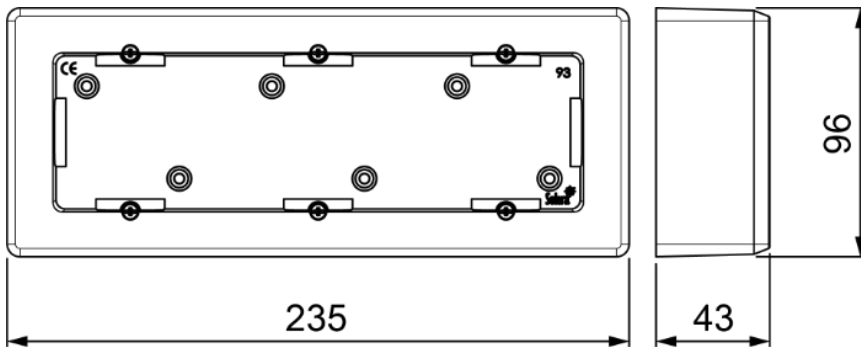



Documentation and downloads



Safety Information (0.38MB)