

Lampholder E-27 for fairs. 4A 250V~. Anchor with 5 x 13 mm rectangular

E27 lamp holder for temporary fair setups, fits 5x13 mm cables. Made of black thermoplastic, rated 4A 250V up to 100W. IP44 with rubber gasket for sealing.



Features

Common applications	Indoor domestic / tertiary environment (Interior of home, offices, shops, etc.)
Material	Thermoplastic
Tension	250 V~
Electricity	4 A
Fixation System	Type fair
Maximum power	100W
Color	Black

Technical data

Free of halogens	Yes
------------------	-----

Regulations

CE marking	Yes
UK marking	Yes
CMim marking	Yes
According to Regulations UNE/EN	UNE-EN 60238:2018
In accordance with the Low Voltage Electrotechnical Regulations (REBT)	Yes

According to European Directive 2014/35 / EU. Low voltage directive Yes

Sustainability

According to European Directive 2011/65/UE (RoHS) Yes

According to European Directive 2012/19/UE (RAEE2) Yes

According to Regulations (RoHS) UNE-EN IEC 63000:2022

Logistics and packaging

Unit EAN code 8423220240315

EAN code container 8423220206526

EAN code packaging 18423220206523

Units packaging 5

Units carton 250

Pallet Units 7500

Packaging Measurements cm 25,4x3x14

Packaging Measures cm 50x30x29

Unit weight (g) 18,3

Container Weight (Kg) 0,0937

Packaging Weight (Kg) 5,25

Tariff code 85366110

Sketch

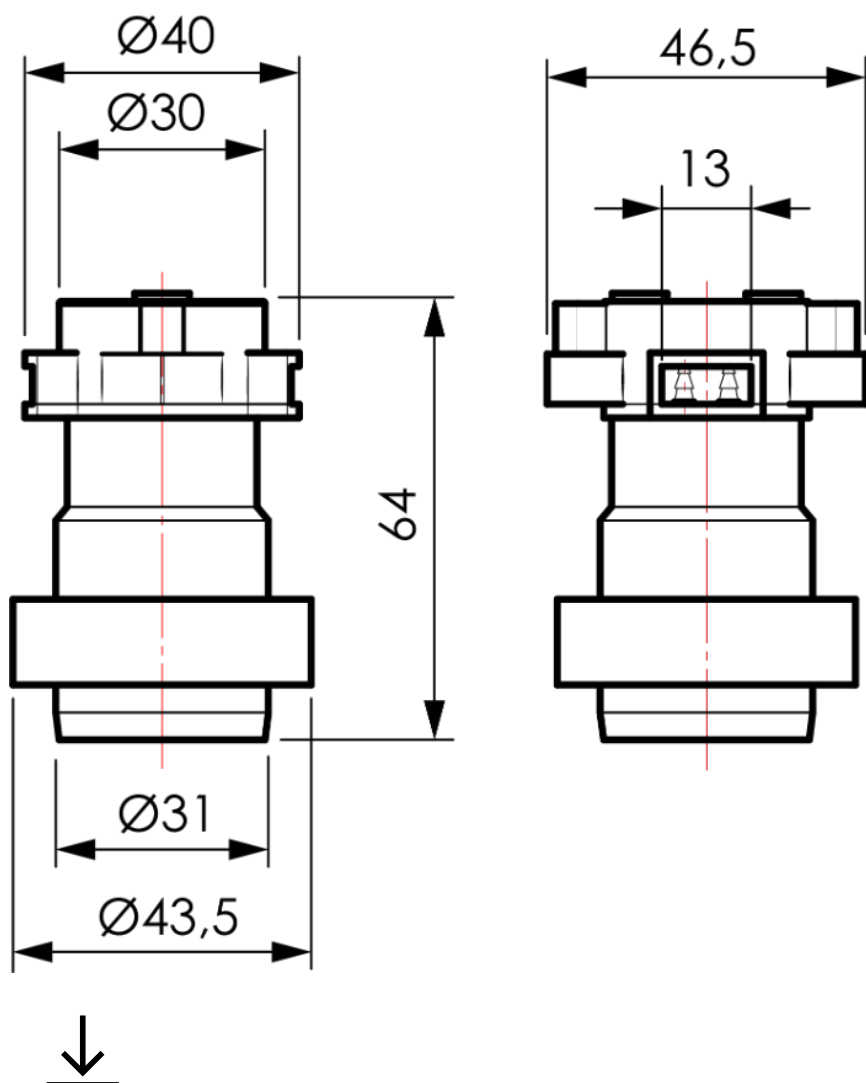

Documentation and downloads



Safety Information (0.38MB)