

Mobile industrial socket 3P+E, 32A 400V~. IP44

Mobile industrial socket 3P+E, 32A 400V~. IP44



Features

| | |
|-----------------------------|---|
| Common applications | Industrial environments (factories, warehouses, etc.) |
| Type | Mobile industrial socket |
| No. of poles | 3P + T |
| Type of terminal connection | Screw connection |
| Earth position | 6h |
| Nominal current | 32A |
| Nominal voltage | 400V |
| Color | Red |

Technical data

| | |
|---------------------------------|------------------|
| Protection Degree (IK) | IK09 |
| Impact shock resistance | Strong |
| Fire resistance (GWEPT) | 850 °C |
| Heat resistance (Ball pressure) | 125 °C |
| Ambient operating temperature | -5 °C ; +40 °C |
| Dimensional stability | -25 °C -> +80 °C |
| Free of halogens | Yes |

Regulations

| | |
|---------------------------------|--|
| CE marking | Yes |
| UK marking | Yes |
| CMim marking | Yes |
| According to Regulations UNE/EN | UNE-EN 60309-1:2023 UNE-EN 60309-2:2023 |

| | |
|--|-----|
| In accordance with the Low Voltage Electrotechnical Regulations (REBT) | Yes |
|--|-----|

| | |
|---|-----|
| According to European Directive 2014/35 / EU. Low voltage directive | Yes |
|---|-----|

Sustainability

| | |
|---|-----|
| According to European Directive 2011/65/UE (RoHS) | Yes |
|---|-----|

| | |
|--|-----|
| According to European Directive 2012/19/UE (RAEE2) | Yes |
|--|-----|

| | |
|---------------------------------|-----------------------|
| According to Regulations (RoHS) | UNE-EN IEC 63000:2022 |
|---------------------------------|-----------------------|

Logistics and packaging

| | |
|---------------|---------------|
| Unit EAN code | 8423220042827 |
|---------------|---------------|

| | |
|--------------------|---------------|
| EAN code container | 8423220042827 |
|--------------------|---------------|

| | |
|--------------------|----------------|
| EAN code packaging | 18423220042824 |
|--------------------|----------------|

| | |
|-----------------|---|
| Units packaging | 1 |
|-----------------|---|

| | |
|--------------|----|
| Units carton | 10 |
|--------------|----|

| | |
|--------------|-------|
| Pallet Units | 99999 |
|--------------|-------|

| | |
|-----------------------|------------|
| Packaging Measures cm | 29x19x16,5 |
|-----------------------|------------|

| | |
|-----------------|-------|
| Unit weight (g) | 245,6 |
|-----------------|-------|

| | |
|-----------------------|--------|
| Container Weight (Kg) | 0,2456 |
|-----------------------|--------|

| | |
|-----------------------|-------|
| Packaging Weight (Kg) | 2,603 |
|-----------------------|-------|

| | |
|-------------|----------|
| Tariff code | 85366990 |
|-------------|----------|

Sketch

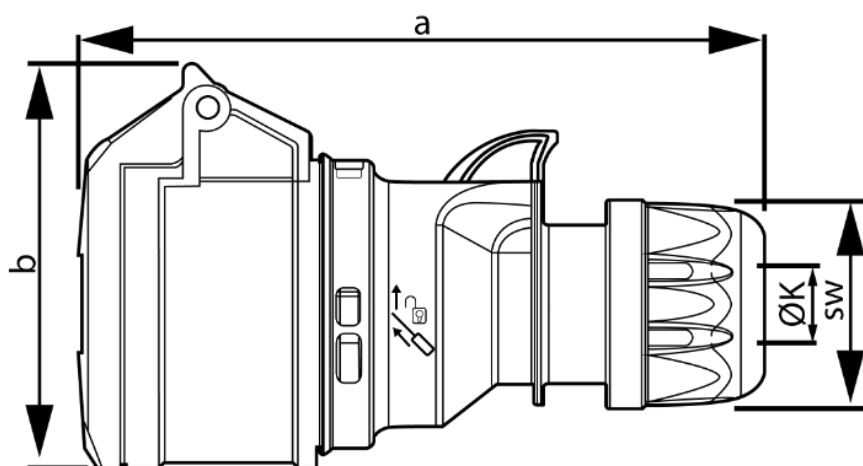

| Ampere | 16 | | | | 32 | | | |
|---------|------|------|------|------|---------|---------|---------|---------|
| Pole | 3 | 4 | 5 | 7 | 3 | 4 | 5 | 7 |
| a [mm] | 133 | 138 | 145 | 145 | 161 | 161 | 168 | 168 |
| b [mm] | 74 | 82 | 89 | 89 | 94 | 94 | 99 | 99 |
| K [mm] | 6-15 | 6-15 | 8-16 | 8-16 | 11,5-20 | 11,5-20 | 11,5-22 | 11,5-22 |
| SW [mm] | 42 | 42 | 42 | 42 | 50 | 50 | 50 | 50 |



Documentation and downloads



Safety Information (0.38MB)