

## Angled industrial flush socket 2P+E, 16A 230V~. IP67.

Flush-mounted industrial base with angled design, 2 poles + earth, rated at 16A 230V~. Its IP67 protection makes it suitable for industrial settings with frequent exposure to dust, moisture, or water jets. The angled layout supports ergonomic plug connection, especially in technical spaces. Ideal for electrical panels, control enclosures, and demanding applications.



### Features

Common applications	Industrial environments (factories, warehouses, etc.)
Type	Fitted socket outlet
No. of poles	2P + T
Type of terminal connection	Screw connection
Earth position	6h
Frame for Indubox	MR1316
Nominal current	16A
Nominal voltage	230V
Color	Blue

### Technical data

Protection Degree (IK)	IK09
Impact shock resistance	Strong
Fire resistance (GWEPT)	850 °C
Heat resistance (Ball pressure)	125 °C
Ambient operating temperature	-5 °C ; +40 °C
Dimensional stability	-25 °C -> +80 °C
Free of halogens	Yes

## Regulations

CE marking	Yes
UK marking	Yes
CMim marking	Yes
According to Regulations UNE/EN	UNE-EN 60309-1:2023 UNE-EN 60309-2:2023
In accordance with the Low Voltage Electrotechnical Regulations (REBT)	Yes
According to European Directive 2014/35 / EU. Low voltage directive	Yes

## Sustainability

According to European Directive 2011/65/UE (RoHS)	Yes
According to European Directive 2012/19/UE (RAEE2)	Yes
According to Regulations (RoHS)	UNE-EN IEC 63000:2022

## Logistics and packaging

Unit EAN code	8423220043008
EAN code container	8423220043008
EAN code packaging	18423220043005
Units packaging	1
Units carton	10
Pallet Units	99999
Packaging Measures cm	29x18,5x14
Unit weight (g)	131,2
Container Weight (Kg)	0,1312
Packaging Weight (Kg)	1,447
Tariff code	85366990

## Sketch

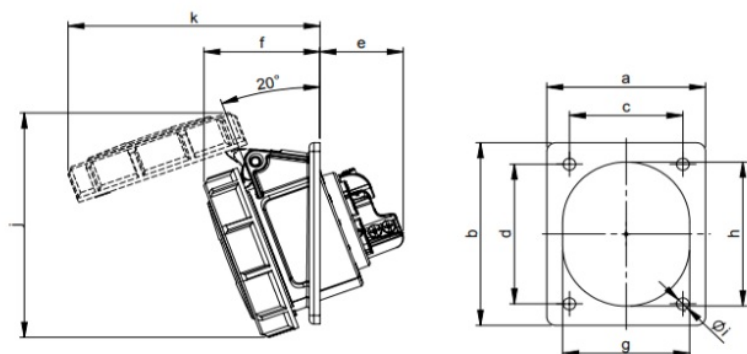

Ampere	16		
Pole	3	4	5
a [mm]	70	70	-
b [mm]	85	85	-
c [mm]	50	50	-
d [mm]	65	65	-
e [mm]	38	38	-
f [mm]	50	52	-
g [mm]	51	56	-
h [mm]	61	67	-
i [mm]	5,5	5,5	-
j [mm]	97	104	-
k [mm]	102	111	-



## Documentation and downloads



Safety Information (0.38MB)