

Industrial flush interlocked socket 3P+N+E, 16A 400V~. IP44

Flush-mounted industrial base with interlock system that prevents accidental disconnection under load. It features 3 poles + neutral + earth, rated at 16A and 400V~. With IP44 protection, it is suitable for industrial environments with moderate dust and humidity. The interlock mechanism ensures power is only enabled after secure plug insertion. Ideal for three-phase equipment, control panels and maintenance areas.



Features

Common applications	Industrial environments (factories, warehouses, etc.)
No. of poles	3P + N + T
Type of terminal connection	Screw connection
Earth position	6h
Interlocking	Yes
Frame for Indubox	MR1300X
Nominal current	16A
Nominal voltage	400V
Color	Red

Technical data

Protection Degree (IK)	IK09
Impact shock resistance	Strong
Fire resistance (GWEPT)	850 °C
Heat resistance (Ball pressure)	125 °C
Ambient operating temperature	-5 °C ; +40 °C
Dimensional stability	-25 °C -> +80 °C

Free of halogens	Yes
------------------	-----

Regulations

CE marking	Yes
------------	-----

UK marking	Yes
------------	-----

CMim marking	Yes
--------------	-----

According to Regulations UNE/EN	UNE-EN 60309-1:2023 UNE-EN 60309-2:2023
---------------------------------	--

In accordance with the Low Voltage Electrotechnical Regulations (REBT)	Yes
--	-----

According to European Directive 2014/35 / EU. Low voltage directive	Yes
---	-----

Sustainability

According to European Directive 2011/65/UE (RoHS)	Yes
---	-----

According to European Directive 2012/19/UE (RAEE2)	Yes
--	-----

According to Regulations (RoHS)	UNE-EN IEC 63000:2022
---------------------------------	-----------------------

Logistics and packaging

Unit EAN code	8423220043336
---------------	---------------

EAN code container	8423220043336
--------------------	---------------

EAN code packaging	18423220043333
--------------------	----------------

Units packaging	1
-----------------	---

Units carton	1
--------------	---

Pallet Units	99999
--------------	-------

Packaging Measures cm	19,5x14x11
-----------------------	------------

Packaging Weight (Kg)	0,7176
-----------------------	--------

Tariff code	85366990
-------------	----------

Sketch

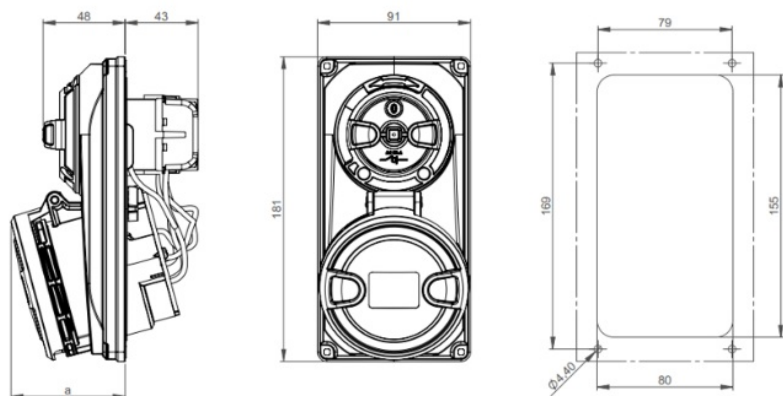

Ampere	16			32		
Pole	3	4	5	3	4	5
a	58	60	61	66	66	67



Documentation and downloads



Safety Information (0.38MB)