

Mobile socket 2P+E , 16A 250V~. White colour.

Mobile socket 2P+E , 16A 250V~. White colour. With handle. Folding cable clamp for easy connection.



Features

Common applications	Indoor domestic / tertiary environment (Interior of home, offices, shops, etc.)
Material	Thermoplastic
Type	Mobile socket
No. of poles	2P + T
Type of terminal connection	Screw connection
Nominal current	16A
Grounding	Side
Folding cable tie to facilitate connection	Yes
Handle	Yes
POssibility to use 3x2.5mm ² cable	Yes
Nominal current	16A
Nominal voltage	250V~
Color	White

Technical data

Fire resistance (GWEPT)	650/750 °C
Heat resistance (Ball pressure)	70/125 °C
Free of halogens	Yes

Regulations

CE marking	Yes
According to Regulations UNE/EN	UNE-20315-1-1:2017; UNE-20315-1-2:2017

In accordance with the Low Voltage Electrotechnical Regulations (REBT)	Yes
--	-----

In accordance with the Regulation (EU) 2023/988 of the European Parliament and of the Council on general product safety	Yes
---	-----

Sustainability

According to European Directive 2011/65/UE (RoHS)	Yes
---	-----

According to European Directive 2012/19/UE (RAEE2)	Yes
--	-----

According to Regulations (RoHS)	UNE-EN IEC 63000:2022
---------------------------------	-----------------------

Logistics and packaging

Unit EAN code	8423220081079
---------------	---------------

EAN code container	8423220079793
--------------------	---------------

EAN code packaging	18423220079790
--------------------	----------------

Units packaging	14
-----------------	----

Units carton	224
--------------	-----

Pallet Units	7840
--------------	------

Packaging Measurements cm	14,5x8,8x19
---------------------------	-------------

Packaging Measures cm	59,5x37,5x20
-----------------------	--------------

Unit weight (g)	45,2
-----------------	------

Container Weight (Kg)	0,6798
-----------------------	--------

Packaging Weight (Kg)	11,4568
-----------------------	---------

Tariff code	85366990
-------------	----------

Sketch

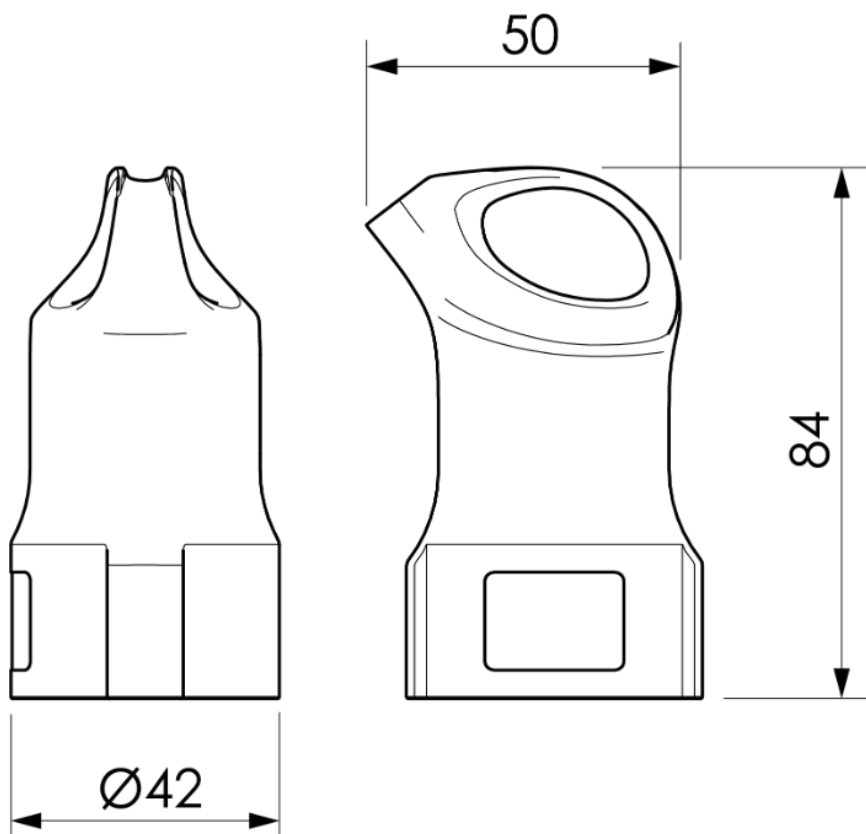

Documentation and downloads



Commercial doc. (0.27MB)



Safety Information (0.38MB)