

Transient surge protection. 230/400V DC (50 - 60 Hz).

Transient surge protection 1000 VDC. Voltage max. 1500VDC. Type II. I nom. décharge 20 kA. I max discharge 40 kA. With auxiliar contacts. Visual status indicator.



Features

Common applications	Indoor domestic / tertiary environment (Interior of home, offices, shops, etc.)
Protection type (modular)	Transient surge protector
No. of poles	2P
Modules (18 mm)	3
Network type	Direct current (c / c)
Fixation	35mm DIN rail
Connection capacity	Up to 35 mm ²
Nominal voltage	1250Vdc

Technical data

Ambient operating temperature	-40 °C ; +85 °C
Free of halogens	Yes

Regulations

CE marking	Yes
UK marking	Yes
CMim marking	Yes
According to Regulations UNE/EN	UNE-EN 50539-11:2013

In accordance with the Low Voltage Electrotechnical Regulations (REBT)	Yes
--	-----

According to European Directive 2014/35 / EU. Low voltage directive	Yes
---	-----

Sustainability

According to European Directive 2011/65/UE (RoHS)	The box does not correspond to the definition of Electrical and Electronical Equipment (EEE), but the included devices are affected individually.
---	---

According to European Directive 2012/19/UE (RAEE2)	The box does not correspond to the definition of Electrical and Electronical Equipment (EEE), but the included devices are affected individually.
--	---

Logistics and packaging

Unit EAN code	8423220227705
---------------	---------------

EAN code container	8423220227705
--------------------	---------------

EAN code packaging	18423220227702
--------------------	----------------

Units packaging	1
-----------------	---

Units carton	30
--------------	----

Pallet Units	1000
--------------	------

Packaging Measurements cm	8x10x4,5
---------------------------	----------

Packaging Measures cm	59,5x37,5x20
-----------------------	--------------

Unit weight (g)	314
-----------------	-----

Container Weight (Kg)	0,364
-----------------------	-------

Packaging Weight (Kg)	10,41
-----------------------	-------

Tariff code	85362010
-------------	----------

Sketch

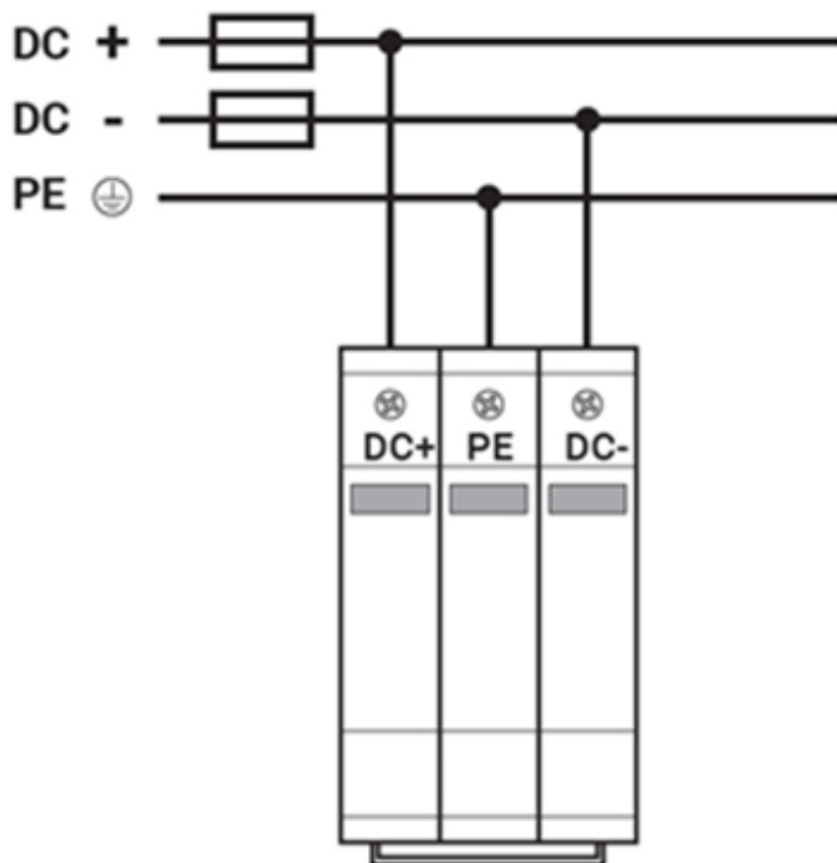

Sketch



Documentation and downloads



Safety Information (0.38MB)